

## QSFP28

### EQ231X0-3LCDB10

#### 100G QSFP28 LR4 10KM Optical Transceiver

- Compliant with 100GBASE-LR4
- Support line rates from 103.125 Gb/s to 111.81 Gb/s
- Integrated LAN WDM TOSA / ROSA for up to 10 km reach over SMF
- 4x25G electrical interface (OIF CEI-28G-VSR) and 4-lane 25.78Gb/s optical interface
- Duplex LC optical receptacle
- Support Digital Diagnostic Monitoring interface
- No external reference clock
- RoHS-10 compliant and lead-free
- Compliant with QSFP28 MSA with LC connector
- Single +3.3V power supply
- Maximum power consumption 3.5W
- All-metal housing for superior EMI performance
- Case operating temperature

Commercial: 0 ~ +70°C

Extended: -10 ~ +80°C

Industrial: -40 ~ +85°C



## Applications

- Data Center
- Local Area Network (LAN)
- Ethernet switches and router applications

## Description

100G QSFP28 LR4 optical Transceiver integrates receiver and transmitter path on one module. In the transmit side, four lanes of serial data streams are recovered, retimed, and passed to four laser drivers. The laser drivers control 4- Distributed Feedback Laser (DFB) with center wavelength of 1296 nm, 1300nm, 1305nm and 1309 nm. The optical signals are multiplexed to a single –mode fiber through an industry standard LC connector. In the receive side, the four lanes of optical data streams are optically de-multiplexed by the integrated optical de-multiplexer. Each data stream is recovered by a PIN photo-detector and trans-impedance amplifier, retimed. This module features a hot-pluggable electrical interface, low power consumption and MDIO management interface.

The product is designed with form factor, optical/electrical connection and digital diagnostic interface according to the QSFP28 Multi-Source Agreement (MSA) and compliant to IEEE 802.3bm.

## Absolute Maximum Ratings

It has to be noted that the operation in excess of any individual absolute maximum ratings might cause permanent damage to this module.

Parameter	Symbol	Min	Max	Unit	Notes
Storage Temperature	T <sub>s</sub>	-40	85	°C	
Power Supply Voltage	V <sub>CC</sub>	-0.3	4.0	V	
Relative Humidity (non-condensation)	RH	5	95	%	
Damage Threshold	TH <sub>d</sub>	5.0		dBm	

## Recommended Operating Conditions and Power Supply Requirements

Parameter	Symbol	Min	Typical	Max	Unit	Notes
Operating Case Temperature	T <sub>OP</sub>	0		70	°C	commercial
		-10		80		extended
		-40		85		Industrial
Power Supply Voltage	V <sub>CC</sub>	3.135	3.3	3.465	V	
Data Rate, each Lane			25.78125		Gb/s	

Control Input Voltage High		2		Vcc	V	
Control Input Voltage Low		0		0.8	V	
Link Distance (SMF)	D			10	km	9/125um

## Pin Assignment and Pin Description

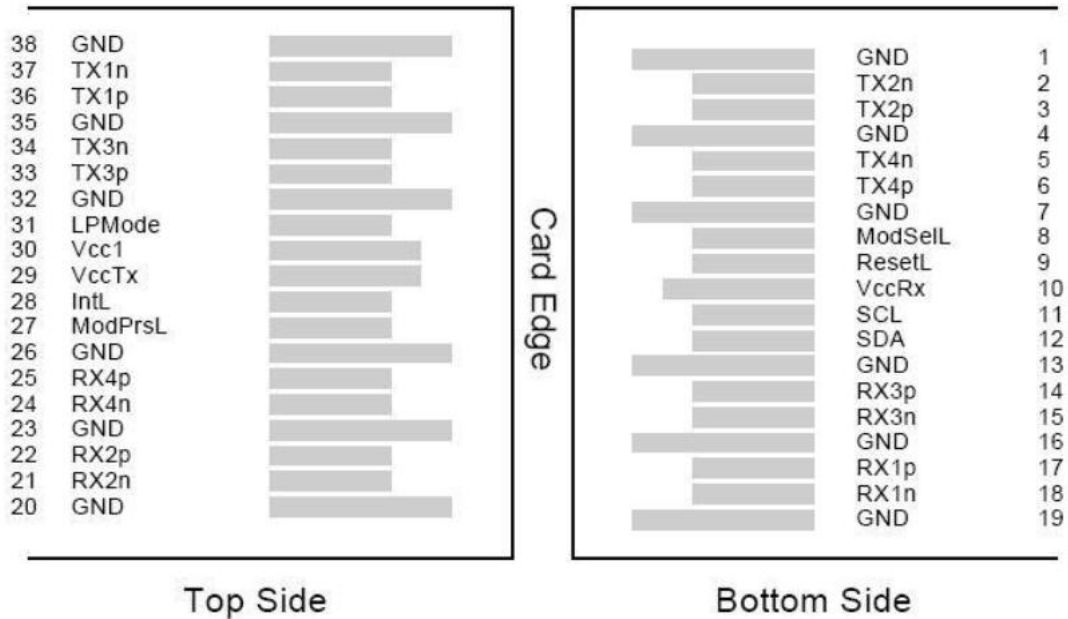

Figure1. Diagram of host board connector block pin numbers and names

Pin	Symbol	Name/Description	Notes
1	GND	Transmitter Ground (Common with Receiver Ground)	1
2	Tx2n	Transmitter Inverted Data Input	
3	Tx2p	Transmitter Non-Inverted Data output	
4	GND	Transmitter Ground (Common with Receiver Ground)	1
5	Tx4n	Transmitter Inverted Data Input	
6	Tx4p	Transmitter Non-Inverted Data output	
7	GND	Transmitter Ground (Common with Receiver Ground)	1
8	ModSelL	Module Select	
9	ResetL	Module Reset	
10	VccRx	3.3V Power Supply Receiver	2
11	SCL	2-Wire serial Interface Clock	

12	SDA	2-Wire serial Interface Data	
13	GND	Transmitter Ground (Common with Receiver Ground)	
14	Rx3p	Receiver Non-Inverted Data Output	
15	Rx3n	Receiver Inverted Data Output	
16	GND	Transmitter Ground (Common with Receiver Ground)	1
17	Rx1p	Receiver Non-Inverted Data Output	
18	Rx1n	Receiver Inverted Data Output	
19	GND	Transmitter Ground (Common with Receiver Ground)	1
20	GND	Transmitter Ground (Common with Receiver Ground)	1
21	Rx2n	Receiver Inverted Data Output	
22	Rx2p	Receiver Non-Inverted Data Output	
23	GND	Transmitter Ground (Common with Receiver Ground)	1
24	Rx4n	Receiver Inverted Data Output	1
25	Rx4p	Receiver Non-Inverted Data Output	
26	GND	Transmitter Ground (Common with Receiver Ground)	1
27	ModPrsl	Module Present	
28	IntL	Interrupt	
29	VccTx	3.3V power supply transmitter	2
30	Vcc1	3.3V power supply	2
31	LPMODE	Low Power Mode	
32	GND	Transmitter Ground (Common with Receiver Ground)	1
33	Tx3p	Transmitter Non-Inverted Data Input	
34	Tx3n	Transmitter Inverted Data Output	
35	GND	Transmitter Ground (Common with Receiver Ground)	1
36	Tx1p	Transmitter Non-Inverted Data Input	
37	Tx1n	Transmitter Inverted Data Output	
38	GND	Transmitter Ground (Common with Receiver Ground)	1

## Notes:

1. GND is the symbol for signal and supply (power) common for QSFP28 modules. All are common within the QSFP28 module and all module voltages are referenced to this potential unless otherwise noted. Connect these directly to the host board signal common ground plane.

2. VccRx, Vcc1 and VccTx are the receiving and transmission power suppliers and shall be applied concurrently. Recommended host board power supply filtering is shown below. Vcc Rx, Vcc1 and Vcc Tx may be internally connected within the QSFP28 transceiver module in any combination. The connector pins are each rated for a maximum current of 500mA.

## Electrical Characteristics

The following electrical characteristics are defined over the Recommended Operating Environment unless otherwise specified.

Parameter	Symbol	Min.	Typ.	Max	Unit	Notes
Power Consumption	p			3.5	W	
Supply Current	Icc			1060	mA	
<b>Transmitter</b>						
Single-ended Input Voltage Tolerance	Vcc	-0.3		4.0	V	
Differential Input Voltage Swing	V <sub>in,pp</sub>	180		1000	mVpp	
Differential Input Impedance	Z <sub>in</sub>	90	100	110	Ohm	1
Transmit Disable Assert Time				10	us	
Transmit Disable Voltage	V <sub>dis</sub>	V <sub>cc</sub> -1.3		V <sub>cc</sub>	V	
Transmit Enable Voltage	V <sub>en</sub>	V <sub>ee</sub>		V <sub>ee</sub> +0.8	V	2
<b>Receiver</b>						
Differential Output Voltage Swing	V <sub>out,pp</sub>	300		850	mVpp	
Differential Output Impedance	Z <sub>out</sub>	90	100	110	Ohm	3
Data output rise/fall time	T <sub>r</sub> /T <sub>f</sub>	28			ps	4
LOS Assert Voltage	V <sub>losH</sub>	V <sub>cc</sub> -1.3		V <sub>cc</sub>	V	5
LOS De-assert Voltage	V <sub>losL</sub>	V <sub>ee</sub>		V <sub>ee</sub> +0.8	V	5

Notes:

1. Connected directly to TX data input pins. AC coupled thereafter.
2. Or open circuit.
3. Input 100 ohms differential termination.
4. These are unfiltered 20-80% values.
5. Loss of Signal is LVTTTL. Logic 0 indicates normal operation; logic 1 indicates no signal detected.

## Optical Characteristics

The following optical characteristics are defined over the Recommended Operating Environment unless otherwise specified.

Parameter	Symbol	Min.	Typical	Max	Unit	Notes
<b>Transmitter</b>						
Lane wavelength (range)	L0	1294.53	1295.56	1296.59	nm	
	L1	1299.02	1300.05	1301.09	nm	
	L2	1303.54	1304.58	1305.63	nm	
	L3	1308.09	1309.14	1310.09	nm	
Signaling rate, each lane			25.78125		GBd	
Side-mode suppression ratio	SMSR	30				
Total launch power				10.5	dBm	
Average launch power, each lane	Pavg	-4.3		4.5	dBm	
Extinction Ratio	ER	4			dB	
Transmitter and Dispersion Penalty, each lane	TDP			2.2	dB	
OMA minus TDP, each lane	OMA-TDP	-2.3			dBm	
Average launch power of OFF transmitter, each lane				-30	dBm	
Transmitter reflectance				-12	dB	
Transmitter eye mask {X1, X2,X3, Y1, Y2, Y3}		{0.25, 0.4, 0.45, 0.25, 0.28, 0.4}				
<b>Receiver</b>						
Signaling rate, each lane			25.78125		GBd	
Receiver Sensitivity per lane	Rsen			-10.6	dBm	1
Input Saturation Power (overload)	Psat			4.5	dBm	

LOS Assert	LOSA	-30			dBm	
LOS De-assert	LOSD			-12		
Receiver reflectance	Rr			-26		
LOS Hysteresis		0.5		4	dB	

Notes:

Measured with a PRBS 231-1 test pattern, @25.78Gb/s, BER<10<sup>-12</sup>.

## Digital Diagnostic Functions

The following digital diagnostic characteristics are defined over the normal operating conditions unless otherwise specified.

Parameter	Symbol	Min.	Max	Unit	Notes
Temperature monitor absolute error	DMI_Temp	-3	3	degC	Over operating temp
Supply voltage monitor absolute error	DMI_VCC	-0.15	0.15	V	Full operating range
RX power monitor absolute error	DMI_RX	-2	2	dB	
Bias current monitor	DMI_bias	-10%	10%	mA	
TX power monitor absolute error	DMI_TX	-2	2	dB	

## Precautions

- A. This device is susceptible to damage as a result of electrostatic discharge (ESD). A static free environment is highly recommended. Follow guidelines according to proper ESD procedures.
- B. Radiation emitted by laser devices can be dangerous to human eyes. Avoid eye exposure to direct or indirect radiation.

## Mechanical Dimensions

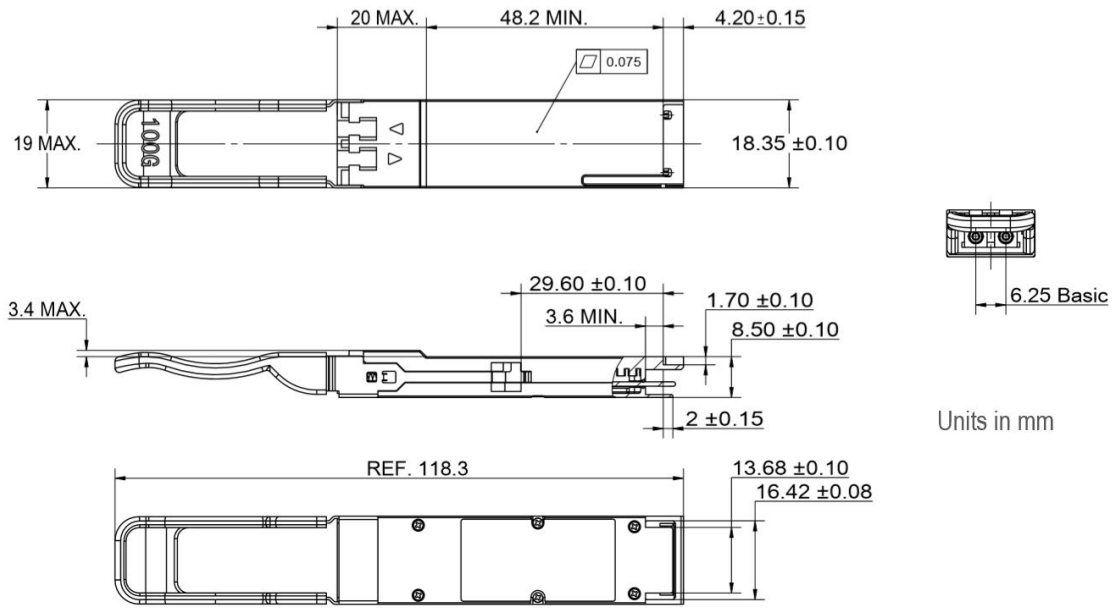

Figure3. Mechanical Outline

## Part Number Ordering Information

Part Number	Data Rate (Gb/s)	Wavelength (nm)	Transmission Distance(km)	Temperature (°C) (Operating Case)
EQ231X0-3LCDB10	103.1	1295.56, 1300.05, 1304.58, 1309.14	10km SMF	0~70 commercial
EQ231X0-3LEDB10	103.1	1295.56, 1300.05, 1304.58, 1309.14	10km SMF	-10~80 Extended
EQ231X0-3LIDB10	103.1	1295.56, 1300.05, 1304.58, 1309.14	10km SMF	-40~85 Industrial



## Compatibility Test

In order to ensure the product compatibility, our products will be tested on the switch before shipment. Our modules can be compatible with many mainstream brand switches, such as Cisco, Juniper, Extreme, Brocade, IBM, H3C, HP, Huawei, D-Link, Mikrotik, ZTE, TP-Link...

Our test equipment: VOLKTEK MEN-4110, HP 2530-8G, CRS226-24G-25+RM, Catalyst 2960G Series, Catalyst 3850 XS 10G SFP+, Catalyst 3750-E Series, HUAWEI S5700Series, H3C S3100V2 Series, Juniper-EX4200, etc.



**Cisco Catalyst 3850**



**HUAWEI S5700**



**H3C S3100V2**



**HP J9264AR**



**Juniper EX 4200**



**Alcatel 6850E-U24X**



**Mikrotik CR5226-24G-25+RM**



**Cisco Catalyst 2960G**



**Volktek MEN-4110**

## Product Production Process

# Quality Assurance

Continuous introduction of new equipment, produced by strict standards, strict quality inspection, to guarantee the high quality standard of each product.



**Standardized  
Production Line**



**Professional  
Welding**



**Assembling**



**Aging Testing**

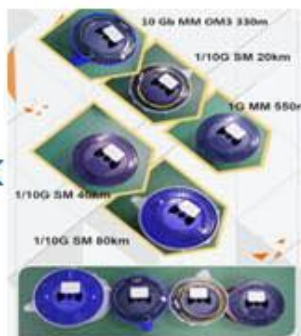

**Distance Testing**



**Cleaning end face**



**Product Initial Test**



**Switch Testing**



**Product Final Test**

## Packaging

ETU-Link provides two kinds of packaging, 10pcs/Tray and individual package.



Company: ETU-Link Technology Co., LTD

Address: Right side of 3rd floor, No. 102 building, Longguan expressway, Dalang street, Longhua District, Shenzhen city, Guangdong Province, China

Tel: +86-755 2328 4603

Addresses and phone number also have been listed at [www.etulinktechnology.com](http://www.etulinktechnology.com).

Please e-mail us at [sales@etulinktechnology.com](mailto:sales@etulinktechnology.com) or call us for assistance.